

webcontrol

LAMINATING MACHINE

webcontrol

WEBCONTROL MACHINERY CORP.

No.1, Jinke 7th Rd., Nantun Dist., Taichung City 40852, Taiwan

TEL: +886-4-23587272 FAX: +886-4-23580882

E-mail: sales@webcontrol.com.tw

www.webcontrol.com.tw

SOLVENTLESS LAMINATION

COMPACT TYPE LME-SF Series

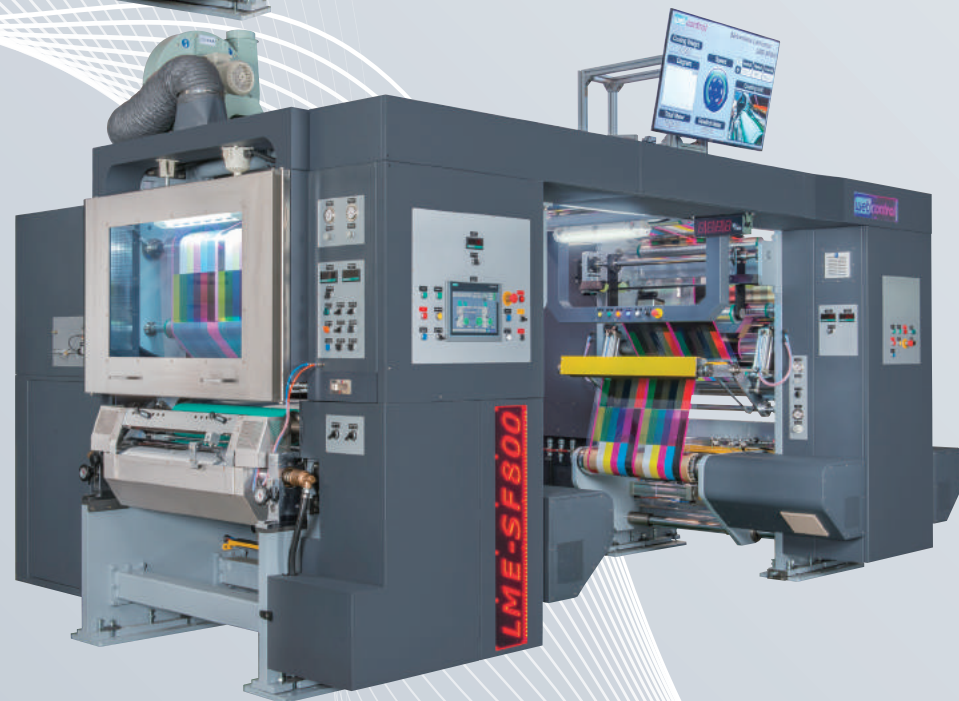

FEATURES

- Reliable Solventless Compact Laminator
- Five Roller Coating System
- Sleeved Transfer Roller
- Three Roller Laminating System
- Easy & Quick Cleaning Coating Station
- Closed Loop Tension Control via Dancer Roller
- Small Foot Print & Short Web Path

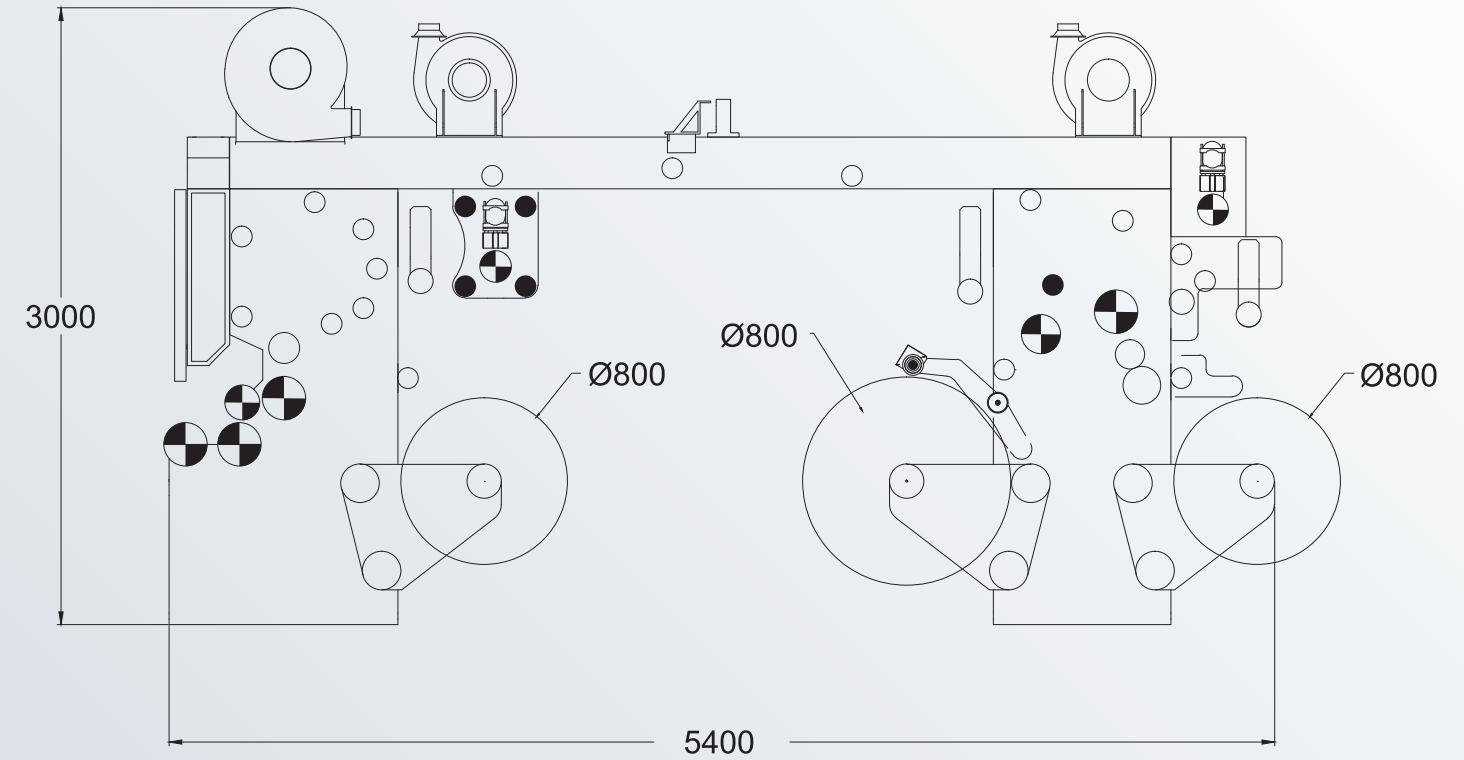

SPECIFICATION

Model	LME-SF
Max. Machine Speed	400 m/min
Shaft Type	Shaftless
Material Width	800 / 1000 / 1300 mm
Min. Material Width	300 / 400 / 500 mm
Max. Coating Width	800 / 1000 / 1300 mm
Min. Coating Width	280 / 380 / 480 mm
1st Unwind Diameter	800 mm
2nd Unwind Diameter	800 mm
Rewind Diameter	800 / 1000 mm
Unwind Paper Core ID	3" (76 mm) & 6" (152 mm)
Rewind Paper Core ID	6" (152 mm)
Unwind Tension System	Auto. Control by Dancing Roller
Rewind Tension System	Auto. Control by Dancing Roller
Coating Tension System	By Load Cell
Dimensions	5400(L) x 3700(W) x 3000 (H) mm

STANDARD

- Adhesive Mixer
- Rewind Lay-on Roller
- Stand Along Thermal Unit
- SIEMENS Control System

OPTION

- Corona Treater
- Adhesive Auto. Refill System
- Real Time Coat Weight Measuring System

SOLVENTLESS LAMINATION

TURRET TYPE LM-SF-T Series

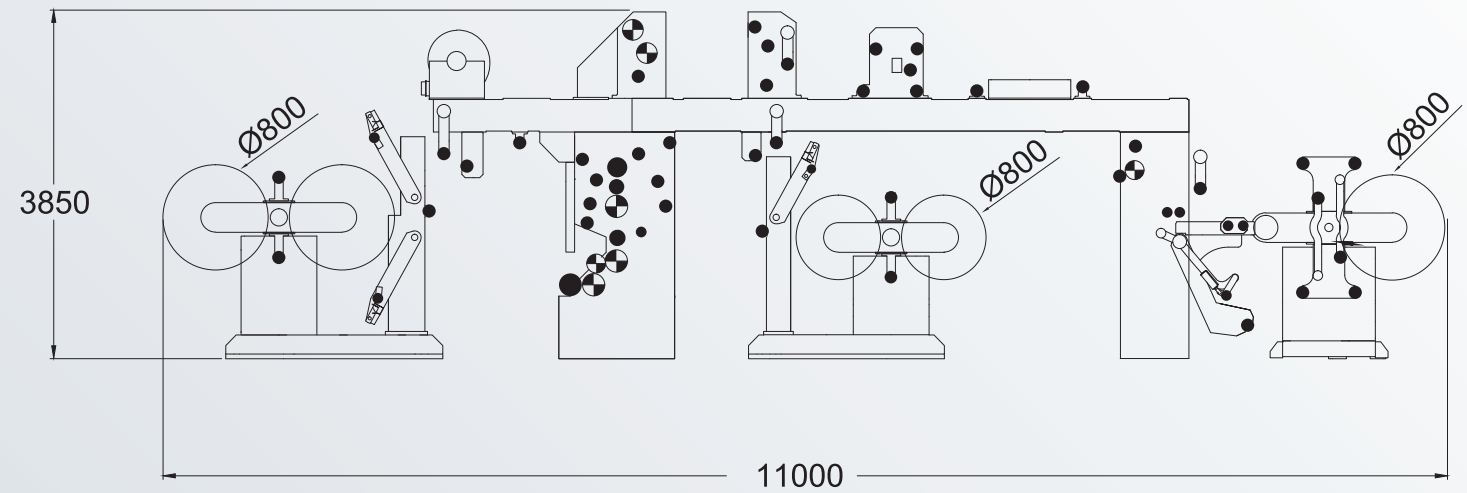
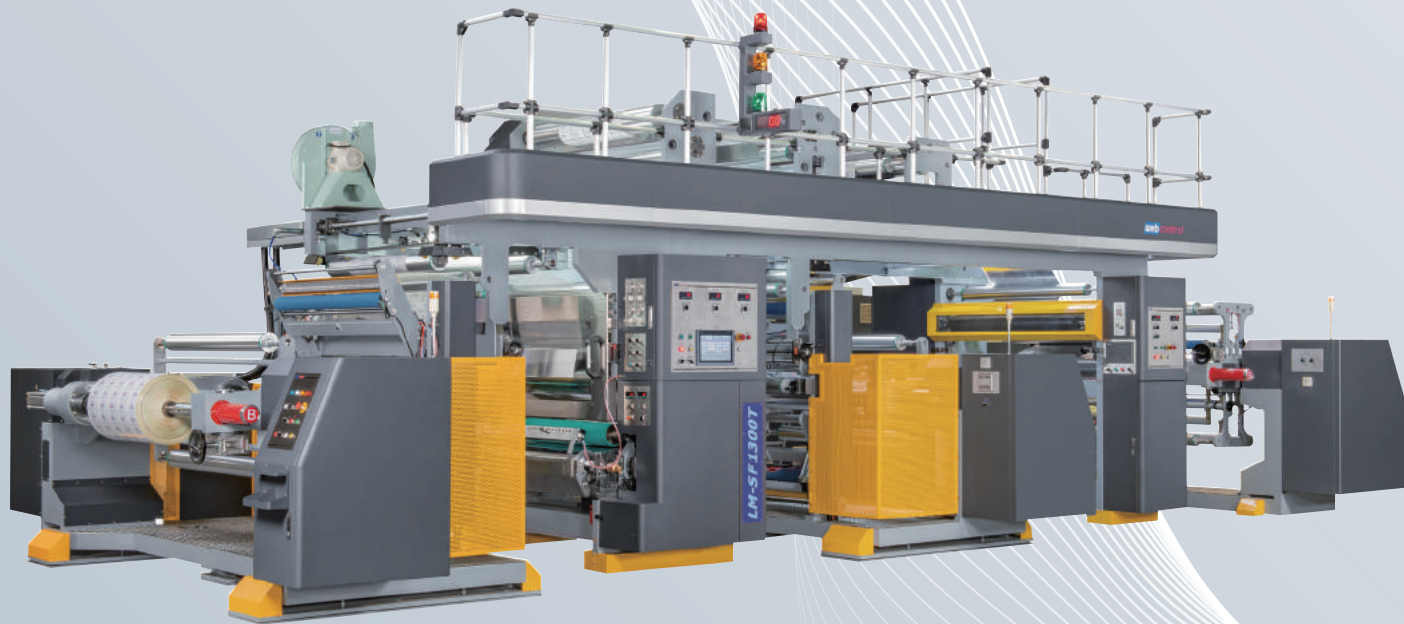

SPECIFICATION

Model	LM-SF-T Series
Max. Machine Speed	400 m/min
Shaft Type	Shaftless
Material Width	1000 / 1300 / 1600 mm
Min. Material Width	400 / 500 / 800 mm
Max. Coating Width	1000 / 13000 / 1600 mm
Min. Coating Width	380 / 480 / 780 mm
1st Unwind Diameter	800 mm
2nd Unwind Diameter	800 mm
Rewind Diameter	800 / 1000 mm
Unwind Paper Core ID	3" (76 mm) & 6" (152 mm)
Rewind Paper Core ID	6" (152 mm)
Coating Tension System	By Load Cell
Dimensions	11000(L) x 6100(W) x 3850 (H) mm

STANDARD

- Adhesive Mixer
- Rewind Lay-on Roller
- SIEMENS Control System

OPTION

- Corona Treater
- Adhesive Auto. Refill System
- Real Time Coat Weight Measuring System
- Bi-direction Splicing

FEATURES

- Low Waste Tracing Roller Solution
- Reliable Full Speed Non-stop Splicing System
- Coating & Laminating Combined Design
- Heavy Duty, Shaftless Unwind & Rewind

WINDING SYSTEM

Model	Center Winding Type with Dual Axes
Cutting Device	Knife Located on Top/Bottom
Edge Guide	Horizontal Adjustment E.P.C. (Unwind)
Tension System	Auto. Control by Dancing Roller

SOLVENT BASED LAMINATION

TURRET TYPE DL Series / DL-S Series

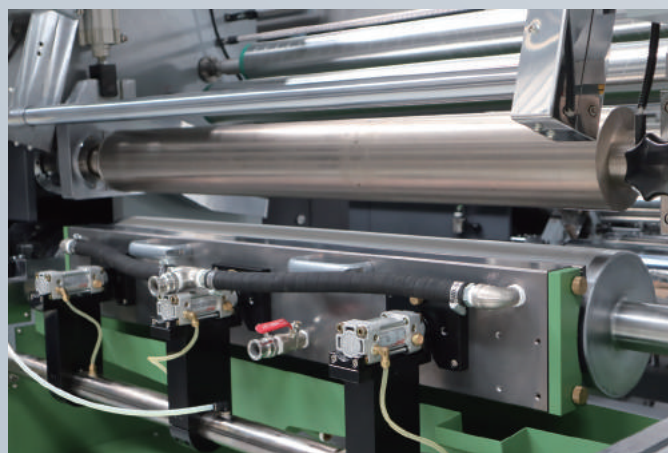
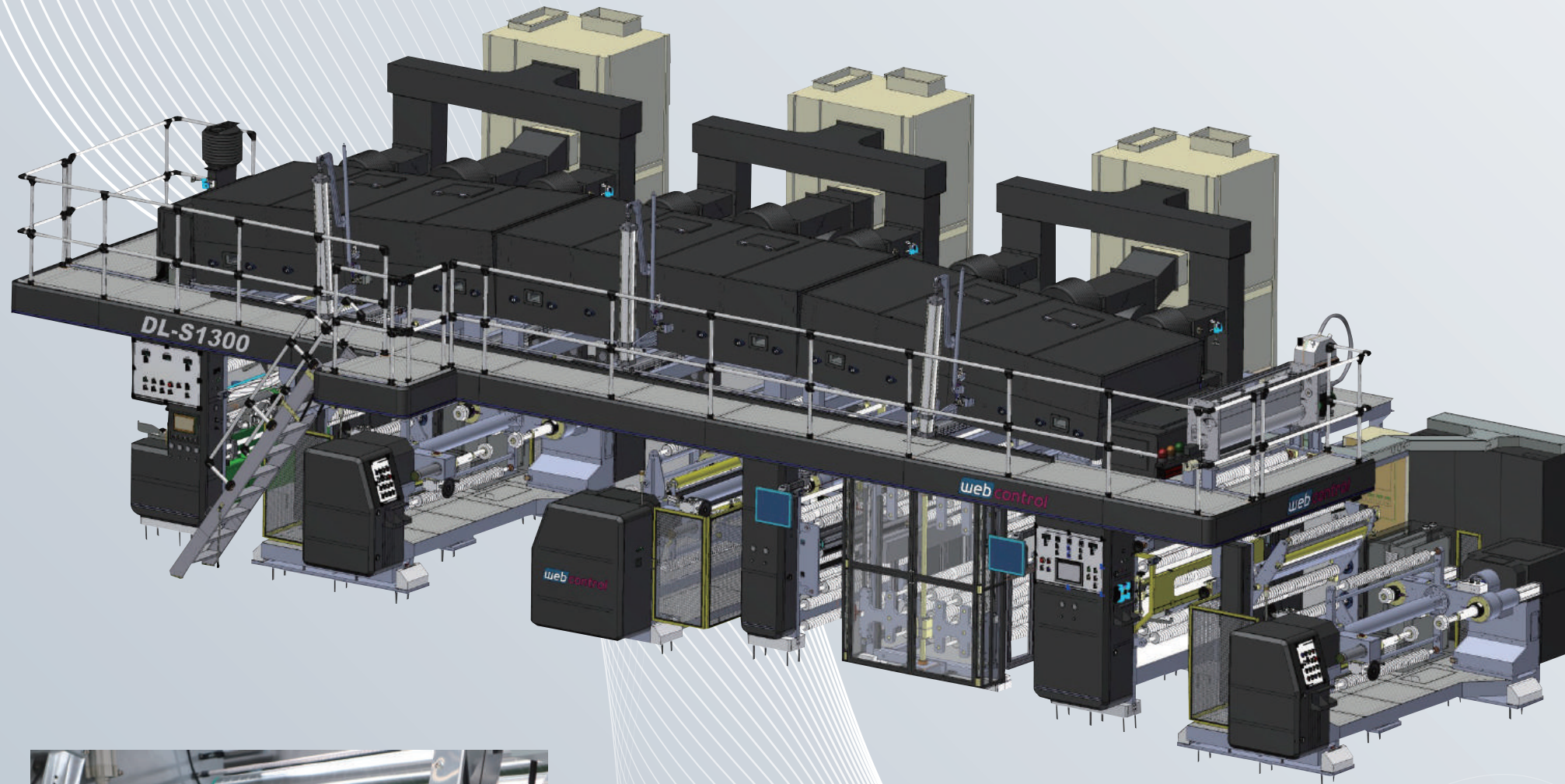
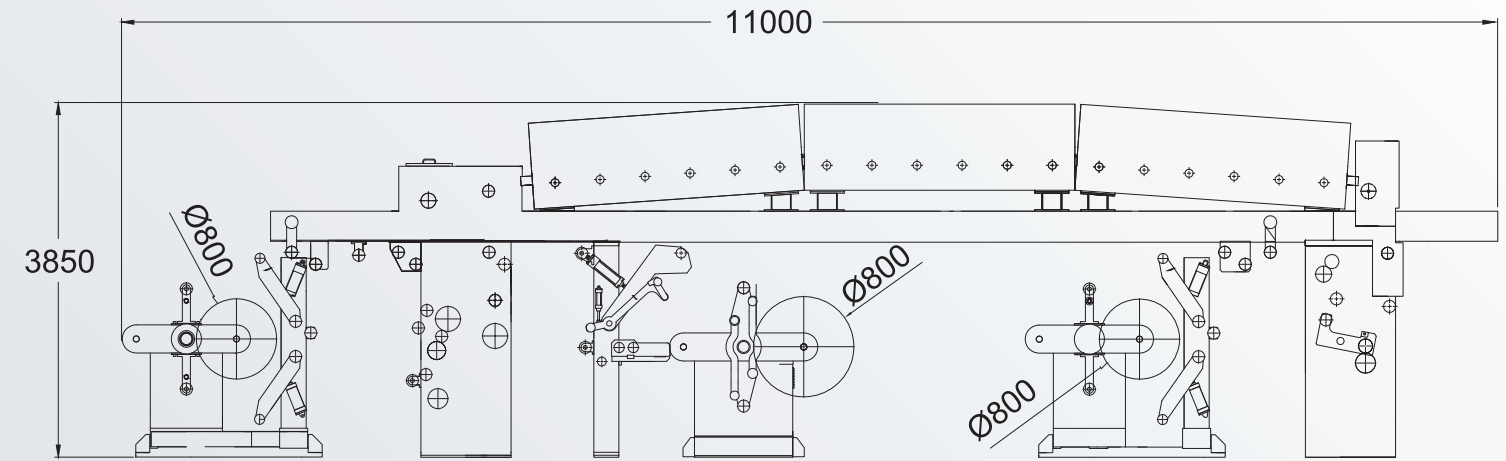

FEATURES

- Precise Laminating Machine
- Low Solvent Retention
- High Efficiency Drying System
- Specialized for Alum. Foil
- Low Waste Full Speed Auto. Splicing

SPECIFICATION

Model	DL Series	DL-S Series
Shaft Type	Shafted	Shaftless
Max. Machine Speed	200 / 250 m/min	
Material Width	1000 / 1300 / 1600 mm	
Max. Coating Width	1000 / 13000 / 1600 mm	
Min. Coating Width	600 mm	
1st Unwind Diameter	800 mm	
2nd Unwind Diameter	800 mm	
Rewind Diameter	800 / 1000 mm	
Unwind Paper Core ID	3" (76 mm) & 6" (152 mm)	
Rewind Paper Core ID	3" (76 mm) & 6" (152 mm)	
Drying Section	3 Sections	
Unwind Tension System	Auto. Control by Dancing Roller	
Rewind Tension System	Auto. Control by Dancing Roller	
Coating Tension System	By Load Cell	
Dimensions	13600(L) x 6650(W) x 4300 (H) mm	

STANDARD

- Rewind Tracing Roller
- Rewind Lay-on Roller
- Double Layer Adhesive Tank
- Open Doctor Blade System
- SIEMENS Control System
- Rotogravure Coating with Individual Motor

OPTION

- Corona Treater
- Bi-direction Splicing
- Chamber Doctor Blade System
- Accumulator for Rewind Splicing
- Real Time Coat Weight Measuring System

COMBI LAMINATION

COMBI PACK READY LM-SFT Series

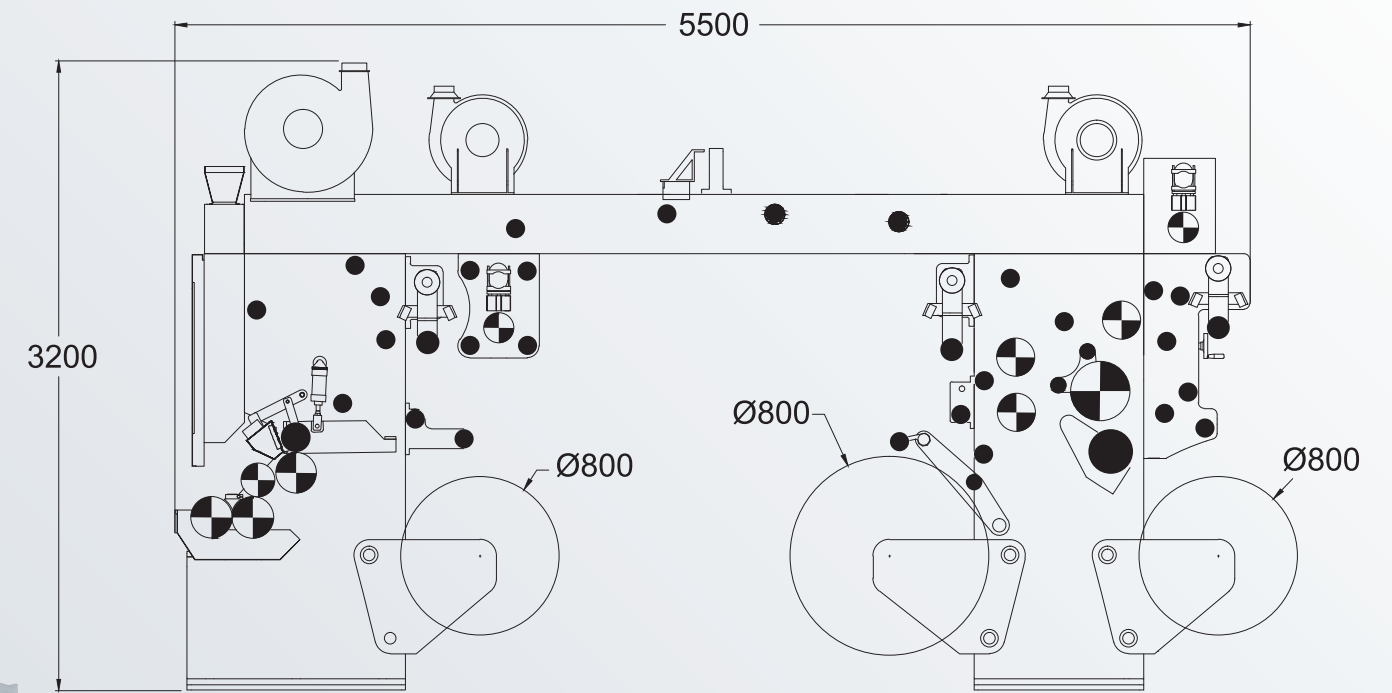
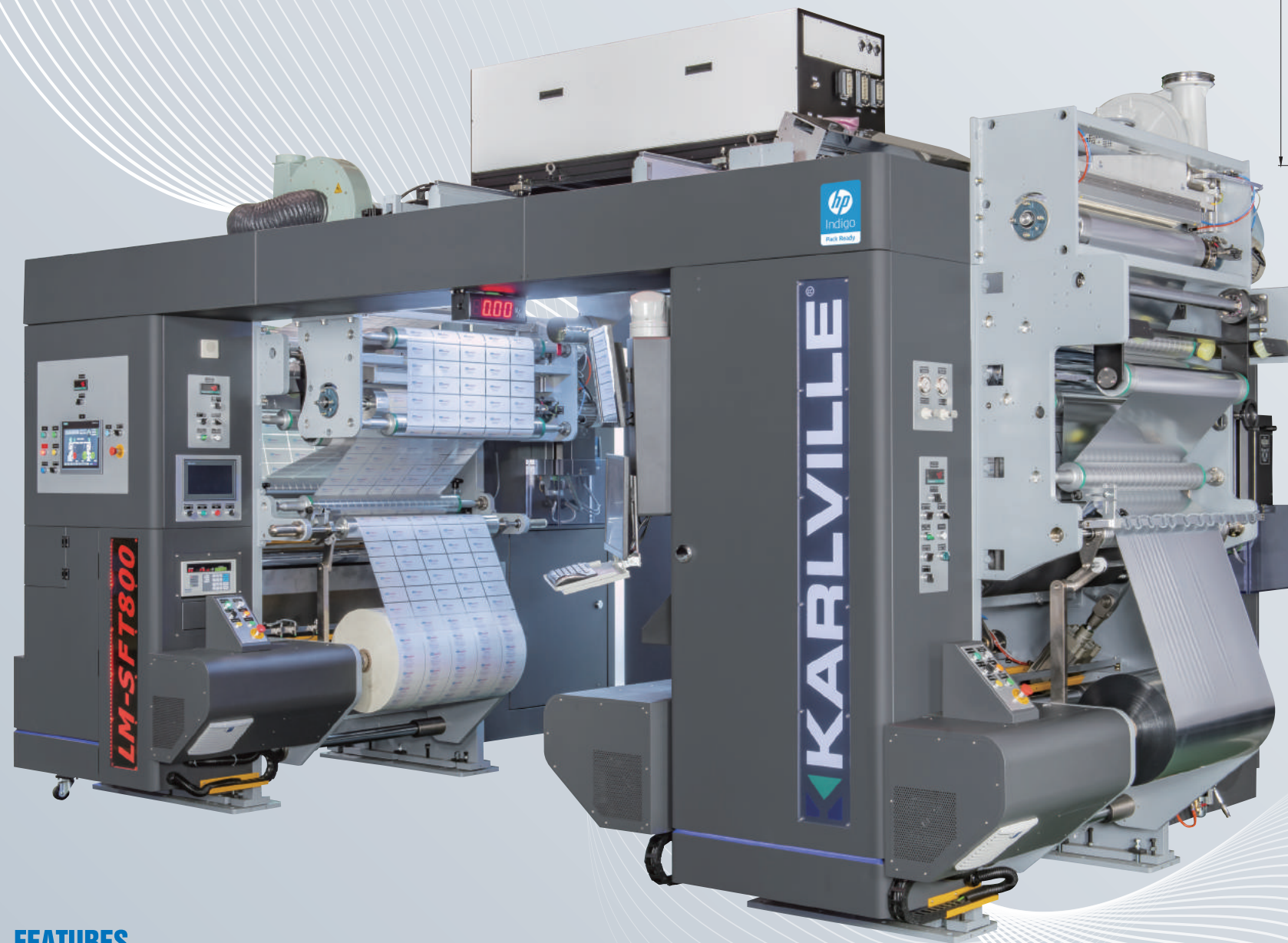

SPECIFICATION

Model	LM-SFT
Max. Machine Speed - Thermal	100 m/min
Max. Machine Speed - Solventless	400 m/min
Shaft Type	Shaftless
Material Width	800 mm
Min. Material Width	300 mm
1st Unwind Diameter	800 mm
2nd Unwind Diameter	800 mm
Rewind Diameter	800 mm
Unwind Paper Core ID	3" (76 mm) & 6" (152 mm)
Rewind Paper Core ID	3" (76 mm) & 6" (152 mm)
Dimensions	5500(L) x 4300(W) x 3200 (H) mm

FEATURES

- Solventless Technology
- Thermal Lamination Integrated

STANDARD

- Adhesive Mixer
- Rewind Lay-on Roller
- Stand Along Thermal Units
- SIEMENS Control System

OPTION

- Corona Treater
- Adhesive Auto. Refill System
- Real Time Coat Weight Measuring System

COMBI LAMINATION

SOLVENT & SOLVENTLESS TYPE LM-COMBI Series

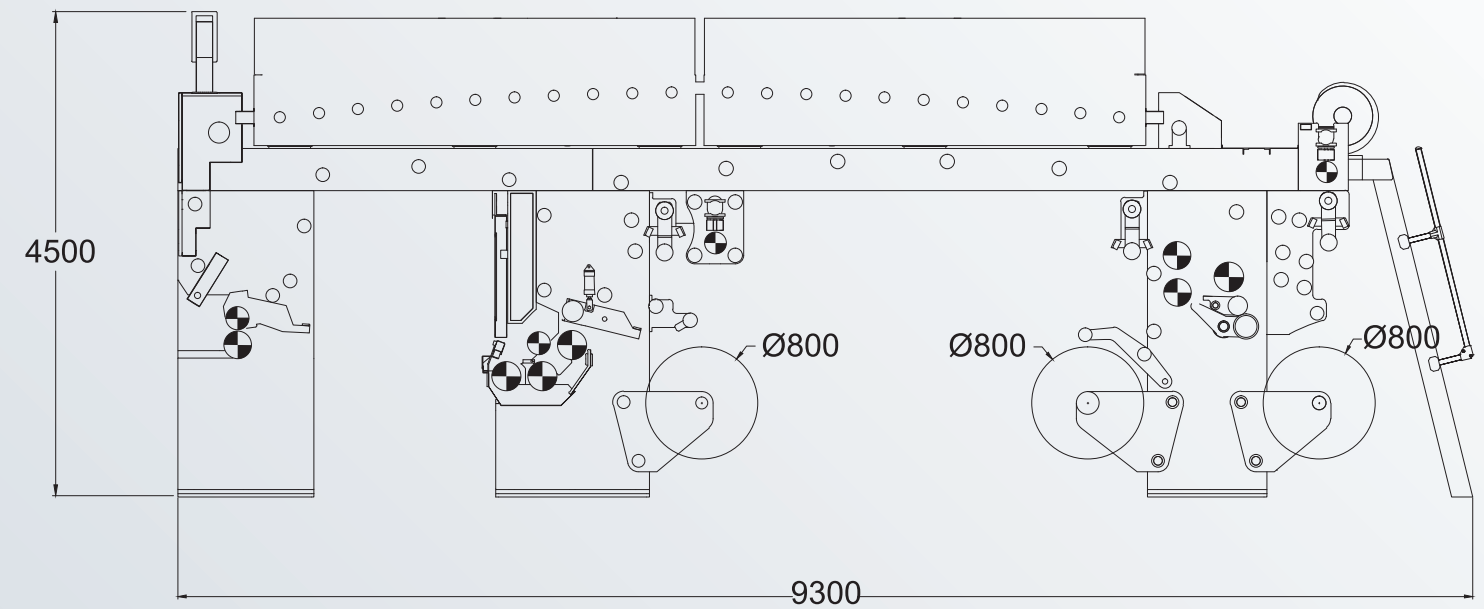
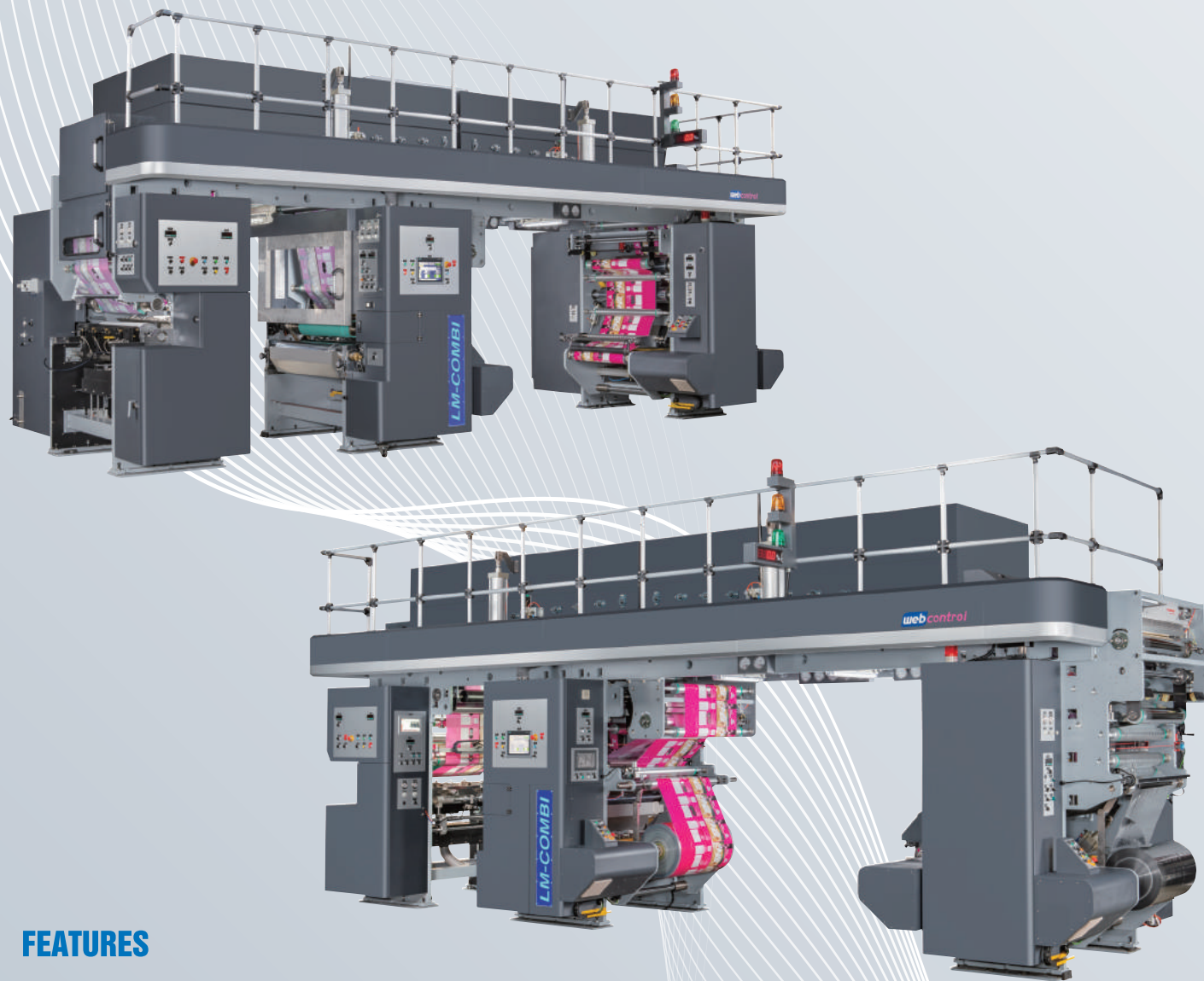

FEATURES

- Stand Along Coating Station
- Solventless Technology
- Solvent/Water Based Technology
- Cold Seal
- High Efficiency Dryer
- Full Registration Solutions



SPECIFICATION

Model	LM-COMBI
Max. Machine Speed	Solvent: 150 m/min, Solventless: 400 m/min
Shaft Type	Shaftless
Material Width	800 / 1000 / 1300 mm
Min. Material Width	300 / 400 / 500 mm
Max. Coating Width	800 / 1000 / 1300 mm
Min. Coating Width	300 / 380 / 500 mm
1st Unwind Diameter	800 mm
2nd Unwind Diameter	800 mm
Rewind Diameter	800 / 1000 mm
Unwind Paper Core ID	3" (76 mm) & 6" (152 mm)
Rewind Paper Core ID	6" (152 mm)
Drying System	2 Sections
Unwind Tension System	Auto. Control by Dancing Roller
Rewind Tension System	Auto. Control by Dancing Roller
Coating Tension System	By Load Cell
Dimensions	9300(L) x 5700(W) x 4500 (H) mm

STANDARD

- Adhesive Mixer
- Rewind Lay-on Roller
- Stand Along Thermal Units
- SIEMENS Control System

OPTION

- Thermal Lamination
- Corona Treater
- Adhesive Auto. Refill System
- Real Time Coat Weight Measuring System
- Cold Seal

THERMAL LAMINATION

TL-800 / TL-C800 Series

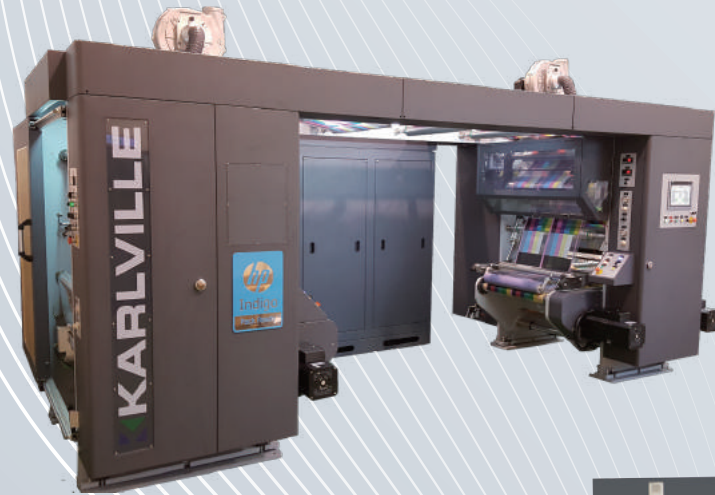

FEATURES

- Thermal Lamination Technology
- For Digital Printing Application
- No adhesive, No Cure Time
- Compact Type Alternative for small job

SPECIFICATION

Model	TL-800	TL-C800
Max. Machine Speed	100 m/min	100 m/min
Shaft Type	Shaftless	Shaft
Material Width	800 mm	800 mm
Min. Material Width	300 mm	300 mm
1st Unwind Diameter	800 mm	600 mm
2nd Unwind Diameter	800 mm	500 mm
Rewind Diameter	800 / 1000 mm	800 mm
Unwind Paper Core ID	3" (76 mm) & 6" (152 mm)	3" (76 mm) 6" (152 mm)-Option
Rewind Paper Core ID	3" (76 mm) & 6" (152 mm)	3" (76 mm) 6" (152 mm)-Option
Dimensions	5700(L) x 3300(W) x 3000 (H) mm	3950(L) x 2800(W) x 2450 (H) mm

STANDARD

- Hot Drum with Thermal Nip Roller
- Adjustable Lamination Angle
- Dual Cooling Roller System
- Stand Along Thermal Units
- Corona Treater
- SIEMENS Control System

OPTION

- Inline Slitting
- Outfeed Tension Control

EXTRUSION LAMINATION

FML-EXL Series

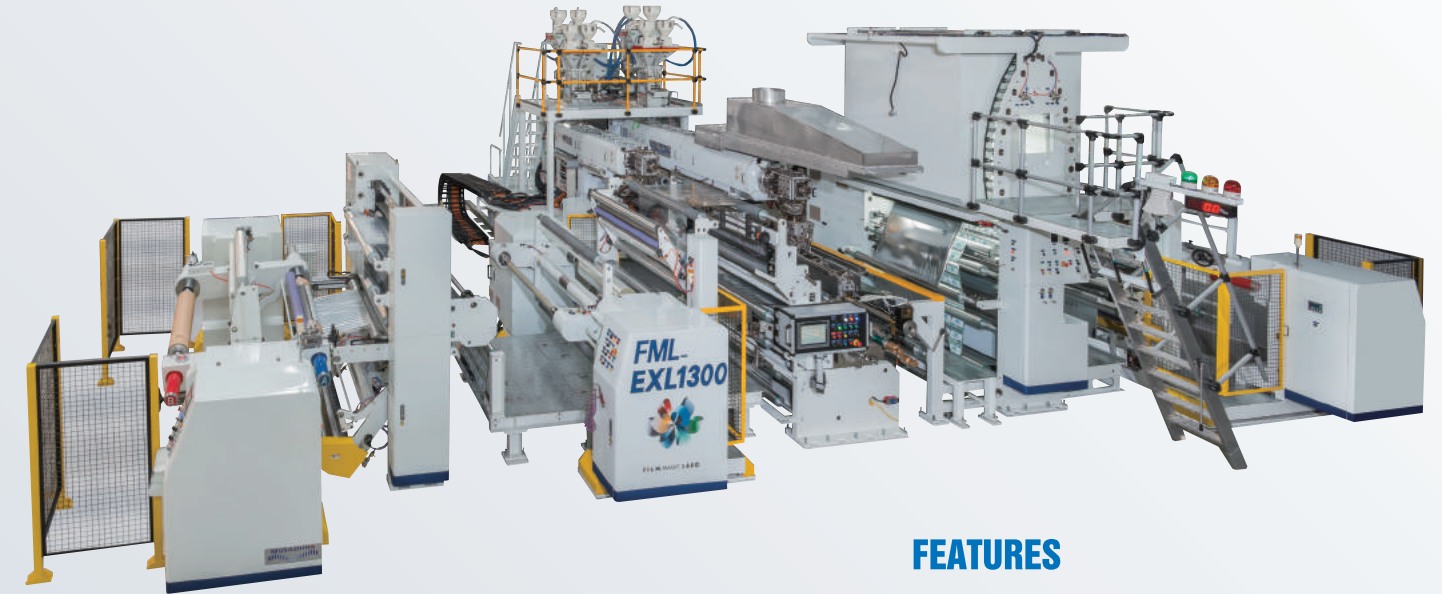

FEATURES

- Extruder/T-die Made in Japan
- Non-waste Winding
- Auto. Splice on Unwind/Rewind
- High Efficient Drying System

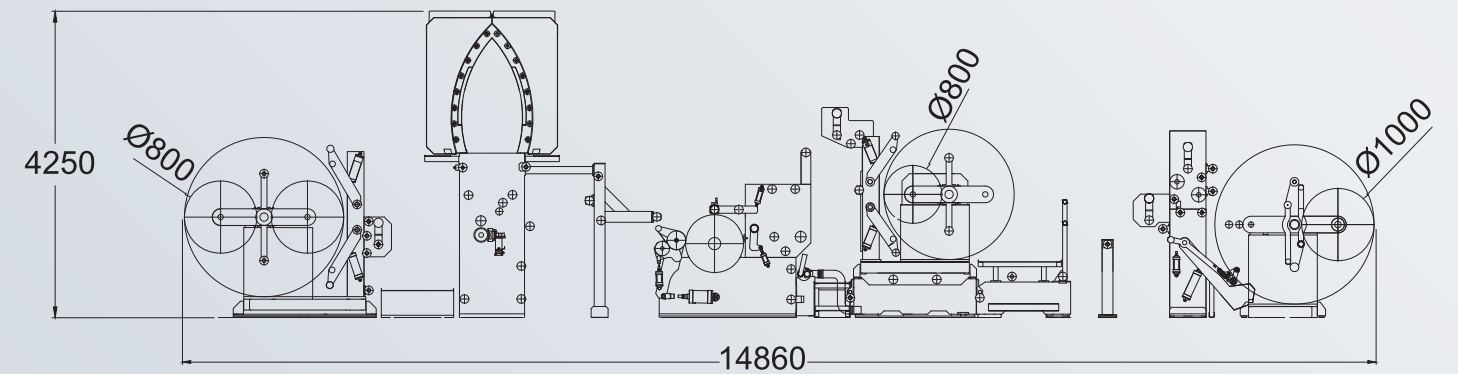

SPECIFICATION

Model	FML-EXL
Max. Machine Speed	300 m/min
Material Width	1300 mm
Min. Material Width	750 mm
Unwind Diameter	800 mm
Auxiliary Unwind Diameter	600 / 800 mm
Rewind Diameter	1000 mm
Drying System	2 Sections
Unwind Tension System	Auto. Control by Dancing Roller
Rewind Tension System	Auto. Control by Dancing Roller
Dimensions	14860(L) x 3850(W) x 4250 (H) mm

OPTION

- Corona Treater
- Chambered Doctor Blade System

WHAT WE CAN DO

Webcontrol dedicate to integrate smart technologies to make machine more flexible, automatic and adaptive. We can bring customer a concept to manage production easily. In addition, we aim to help customer to reduce waste, lower cost, save time to achieve efficient production.

Additional Display

No matter in production room or the office, you can see the machine condition in real time. This display is customizable to show any information of the machine with maximum 1 camera integrated.



Adhesive Measuring System

The coat weight of adhesive is the most critical factor in lamination process. We integrate this non-contact sensor to detect coat weight in real time. Moreover, to export detail report for every finished roll. This system can eliminate the risk of lack of adhesive, and control coat weight precisely to avoid extra cost during production.

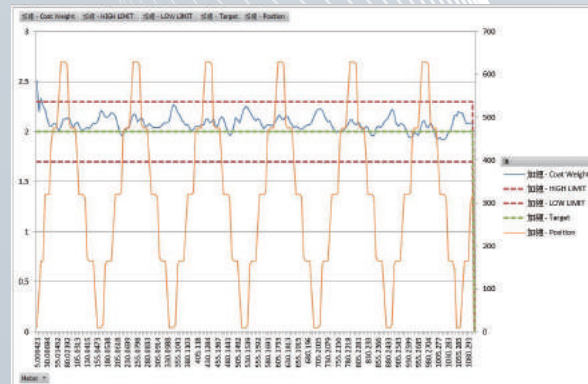

Remote Access

With this remote function, our service team can get access to the machine and provide support instantly. Identifying machine condition and shorten down time as much as possible. Secured connection between machine and server makes your business well protected.

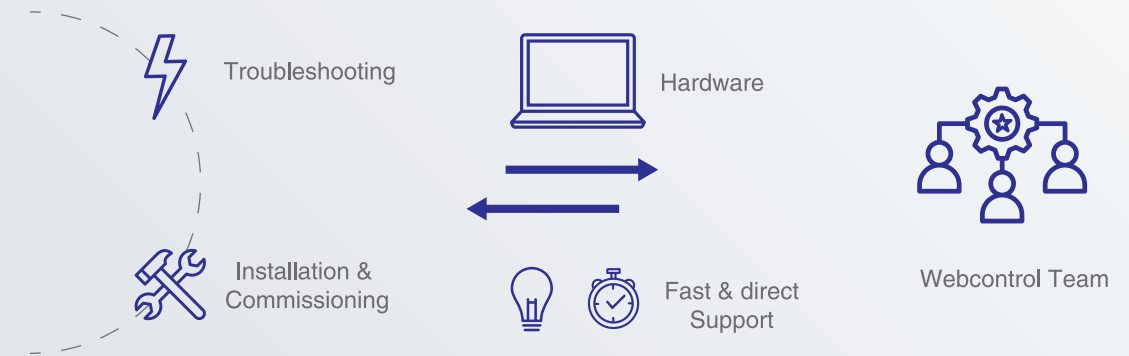

Connectivity

We can help to achieve smart factory by transmitting production data to your system with various protocol available. Store and analyze the data can help to improve production efficiency.

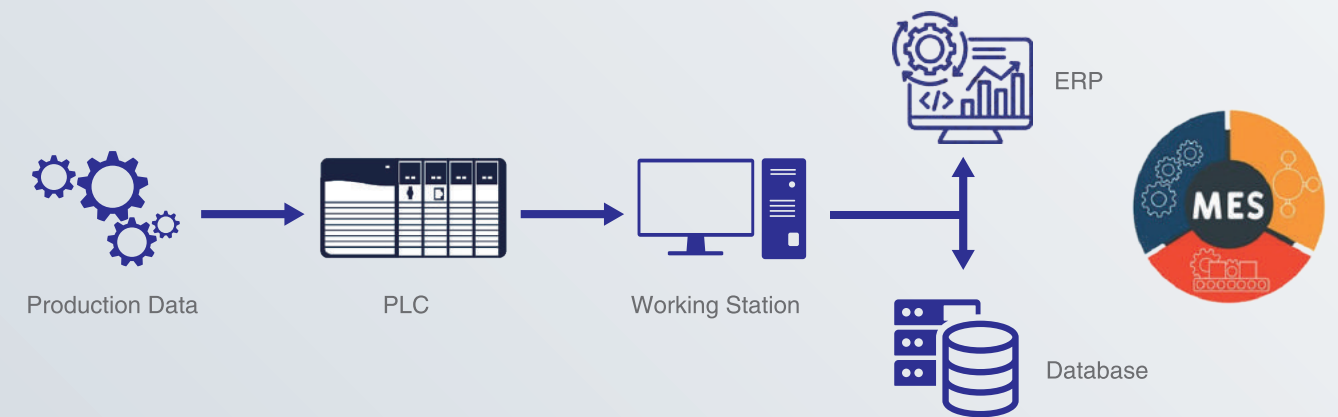

Barcode Scanner

Machine can identify the jobs and change to the built-in recipe automatically. Avoiding mal-operation or mis-setting the parameters. Ensure every job has same setup even with different operators. After job finished, it can print new label with updated information and ready for the next process.

